

TR2730
 POTEAU TREFLE NU D.102MM L.2.73M
 OCTAGONAL POST BARE D.102MM L.2.73M

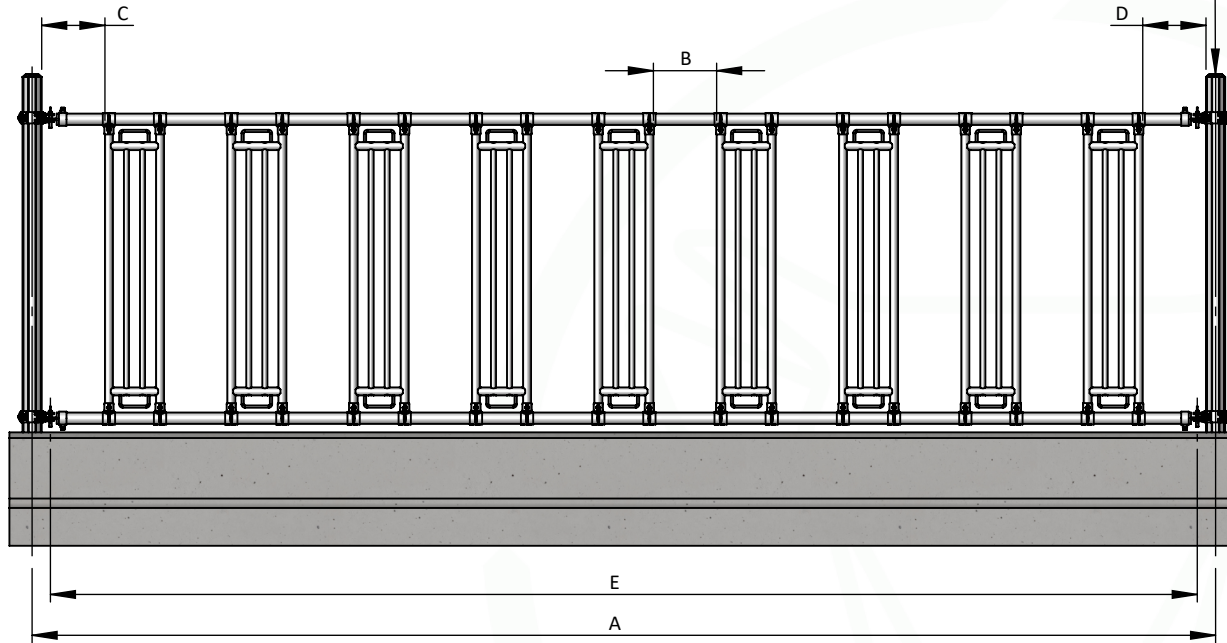

AXE POTEAU AXIS POST	A (mm)	B (mm)	C (mm)	D (mm)	E (mm)	NB. PLACE	NB. MODULE
2m	2260	305	305	305	2065	4	3
3m	3260	266	265	266	3065	6	5
4m	4260	326	327	326	4065	7	6
5m	5260	295	298	295	5065	9	8
6m	6260	334.5	334.5	334.5	6065	10	9

MO0191

1780mm (montage / mounting 1m80)
 1490mm (montage / mounting 1m50)

Ø42mm

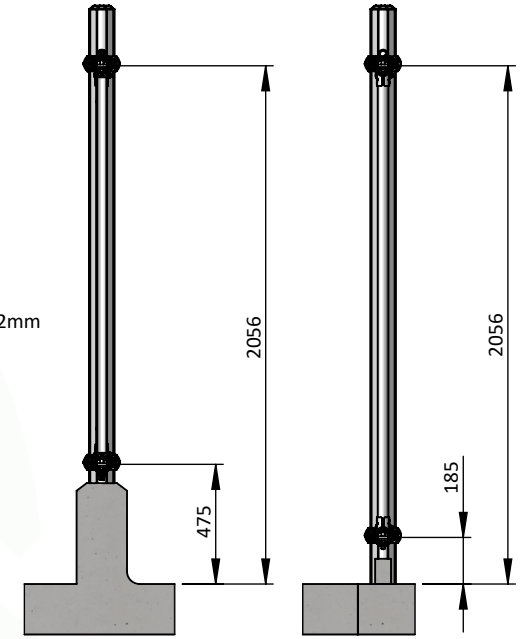

50mm

MO0150

MO0180

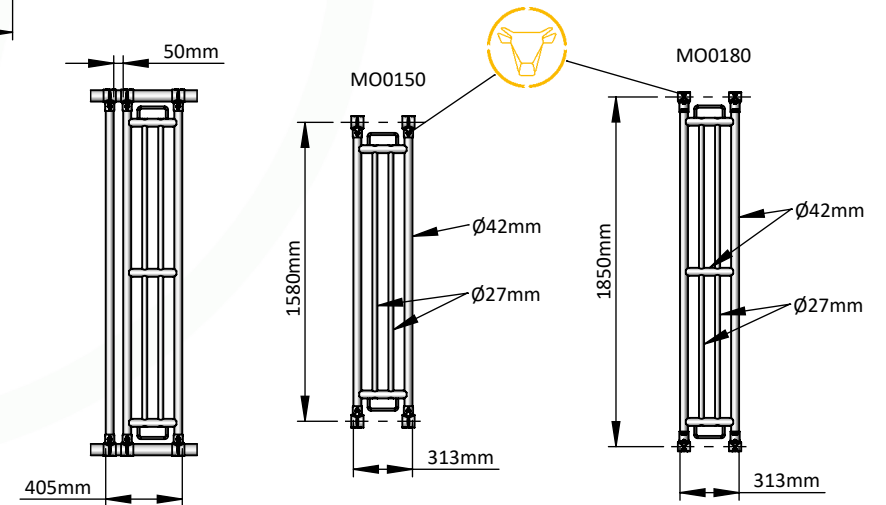

JOURDAIN
 N°1 MONDIAL DU TUBULAIRE BOVIN



JOURDAIN
 INNOVATING

HORSES SELF-SERVICE

Schéma technique donné à titre indicatif, produit pouvant être modifié sans préavis. Nos produits sont brevetés et sont la propriété de JOURDAIN SAS. Consultez nos CGU et instructions de sécurité sur notre site <https://www.jourdain-group.com/fr/documentation>

Technical diagram given for information only, product subject to change without notice. Our products are patented and the property of JOURDAIN SAS. Consult our GTC and safety instructions on our website <https://www.jourdain-group.com/fr/documentation>



DT

18/12/2024